

<b>Freezer System</b>	<b>Refrigeration Specifications</b>	<b>LWSJ100RL4</b>	
Compressor	Water cooled Condensing Unit	Rack Size	Refrigerant
Scroll	208-230/60/1	A	R449A

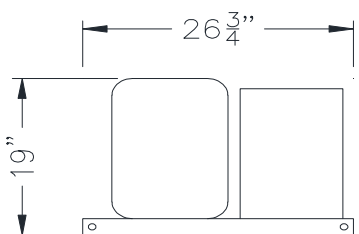

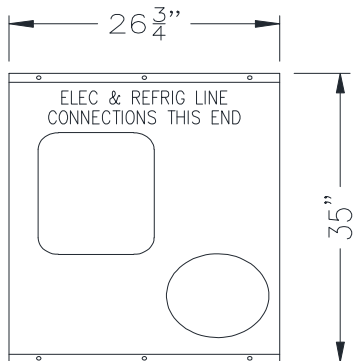



Condensing Unit Specifications							
Water connections: Inlet= 3/8 "		Outlet= 5/8"		GPM @ 75° water = 0.9 GPM	Condenser PSI drop= 0.3 PSI		
Model #	HP	Electical Data		BTU Capacity	Connection sizes		Weight (lbs)
		MCA	MOP	Temp Setpoint -10° @ 105° Cond temp	Liquid (in)	Suction (in)	
LWSJ100RL4	1	19.6	35	6,103	3/8	7/8	117 lbs

Evaporator Unit Cooler  
208-230/60/1

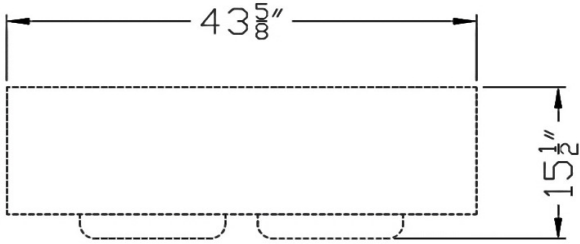

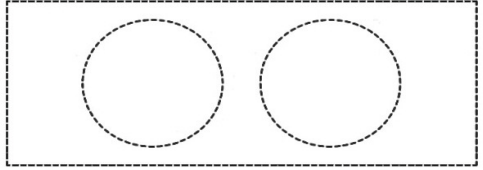

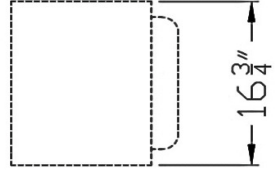

Evaporator Specifications									
Model #	Fan Qty	CFM	Electrical Data (1)			Connection sizes			Weight (lbs)
			MCA	MOP	Elec Defrost Amps	Liquid(in)	Suction(in)	Drain(in)	
WL6E077DDAS	2	1570	9.8	15	9.8	3/8	7/8	3/4	55LBS

Model#	Cond part #	Nominal voltage	MCA	MOP	Weight	<b>NORLAKE</b> ®
<b>LWSJ100RL4</b>	LWSJ100RL4	208-230/60/1	19.6	35	117 lbs	
Heat of Rejection btu/hr	Evap part #	Nominal voltage	MCA	MOP	Weight	
10,848 to H2O, 1,205 to Air	WL6E077DDAS	208-230/60/1	9.8	15	55LBS	