LABORATORY FREEZER

Installation, Operation and Maintenance Instructions

INSPECTION

When the equipment is received, all items should be carefully checked against the bill of lading to insure all crates and cartons have been received. All units should be inspected for concealed damage by uncrating the units immediately. If any damage is found, it should be reported to the carrier at once, and a claim should be filed with the carrier. This equipment has been inspected and tested at the manufacturing facility and has been crated in accordance with transportation rules and guidelines. Manufacturer is not responsible for freight loss or damage.

Before connecting the freezer to the power supply, let it stand for approximately two hours to reduce the possibility of malfunctions in the cooling system due to transport handling

INSTALLATION

GENERAL

After the unit crate and crate base have been removed, use a carpenter's level to level the freezer from front-to-back. Adjust the plastic leveling feet in front ½ bubble higher to ensure that the door closes easily when left halfway open.

Note: It is extremely important that the freezer be level in order to function properly. If the freezer is not properly leveled during installation, the door may be misaligned and not close or seal properly causing cooling, frost or moisture problems. See the illustration below.

Choose a location near a grounded electrical outlet. For the most efficient operation, the freezer should be located where the temperatures will not exceed 110°F (43°C). Temperatures of 32°F (0°C) and below will not affect freezer operation. Additional compressor heaters are not recommended.

Allow adequate space around the unit for good air circulation. A minimum of 3 inches (75 mm) space on all sides of the freezer is required for adequate air circulation.

Note: The exterior walls of the freezer may become quite warm as the compressor works to transfer heat from the interior. Temperatures as much as 30°F (-1°C) warmer than room temperature can be expected. It is particularly important in hotter climates to allow adequate space for air circulation around the freezer.

UNPACKING AND LEVELING UPRIGHT FREEZERS

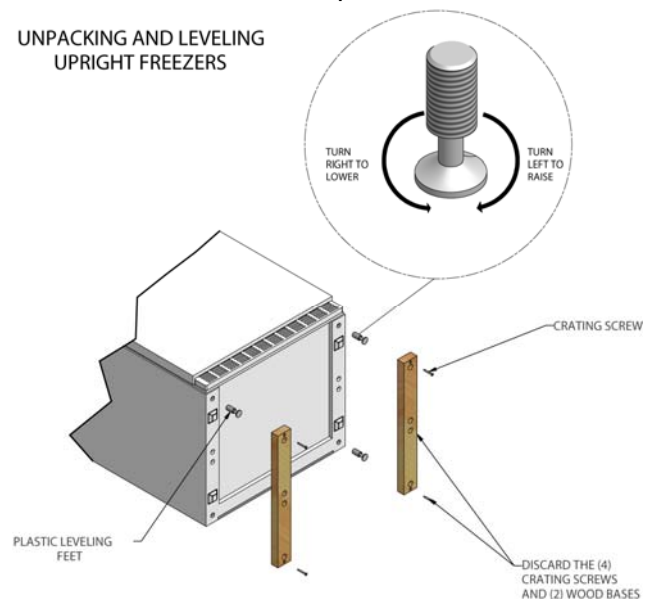

ELECTRICAL

Check the proposed outlet to be used to insure that the voltage, phase, and current carrying capacity of the circuit from the electrical panel correspond to the requirements of the cabinet. **NEVER** use an extension cord or adapter plug to wire any unit. Refer to the serial tag for all pertinent electrical information.

The freezer must be plugged into its own 115 volt, 60 Hz, single phase outlet. The power cord of the freezer is equipped with a three-prong grounding plug for protection against shock hazards. It must be plugged into a properly grounded three-prong receptacle. The receptacles must be installed in accordance with local codes and ordinances.

If voltage varies by more than 10%, freezer performance may be affected. Operating the freezer with insufficient power can damage the compressor.

To prevent the freezer from being accidentally turned off, do not plug the unit into an outlet controlled by a wall switch or pull cord. Do not pinch, knot or bend the cord in any manner.

Observe all Warning Labels. Disconnect power supply to eliminate injury from electrical shock or moving parts when servicing equipment.

OPERATION

Cool Down Period

For safe storage of product, allow a minimum of four hours for the freezer to cool down completely. The freezer will run continuously for the first several hours.

Temperature Control

The temperature control is located inside the freezer. The temperature is factory preset to provide satisfactory product storage temperatures. The temperature control is adjustable to provide a range of temperatures for any desired application. If a colder temperature is required, turn the temperature control knob toward COLDEST and allow several hours for temperatures to stabilize between adjustments. The Automatic Freeze Control feature will maintain proper interior freezer temperature even when the ambient exterior temperature drops to 10°F (-12°C).

Power On Light

The Power On light indicates that the freezer is properly connected to electrical power. The light is energized even when the temperature control is turned to OFF. If the light goes out, refer to the Maintenance Service and Analysis Guide.

Temp Alarm (Audible or Audible with Warning Light)

This feature is designed to provide a warning of a possible malfunction. If the product temperature rises to an unsafe level for long-term storage, the buzzer will sound. The red light, if equipped, will energize. The Temp Alarm feature operates on laboratory/facility electricity. If power fails, the alarm will not function. An On/OFF switch allows the user to deactivate the Temp Alarm when not required. The freezer is shipped with the Temp Alarm in the OFF position. After the freezer has run for at least four hours, the red light, if equipped, will de-energize. The Temp Alarm may then be activated without the alarm sounding. Press the ON switch to activate the Temp Alarm. Press OFF to deactivate the Temp Alarm. If the alarm sounds, ensure that the freezer is properly leveled and the door closes freely and seals properly. If a malfunction is suspected, notify an authorized service technician immediately.

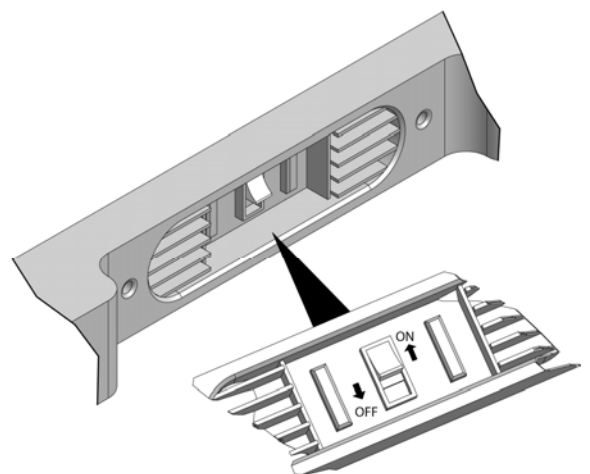

TEMP ALARM - UPRIGHT FREEZERS

Defrost Drain

The defrost drain provides a method of draining the condensate during the defrost cycle and scheduled cleaning. See "Defrosting" in the Periodic Cleaning section.

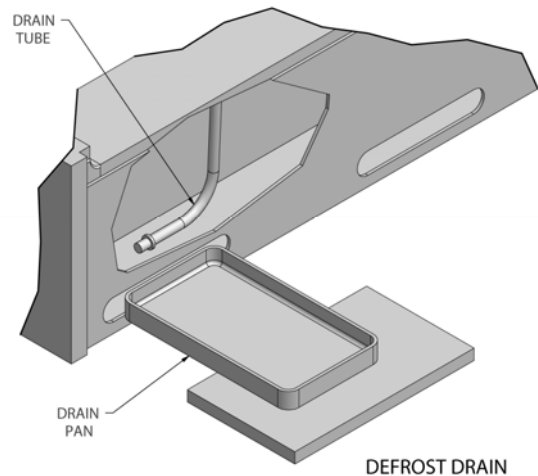

Door Removal

If the door must be removed to fit through a narrow passageway:

1. Lay the freezer on its back on a cover protect its exterior surface.
2. Remove the base panel by unscrewing two screws from the front of the panel.
3. Unplug connector, if required, by holding the cabinet connector in place and pulling the door connector out (see illustration).
4. Remove the bottom hinge screws (see illustration).
5. remove the plastic top hinge cover.
6. Remove screws from the top hinge.
7. Remove the top hinge from the cabinet.
8. Remove the door and bottom hinge from the cabinet.
9. To replace the door, reverse the above order and securely tighten all screws to prevent hinge slippage.

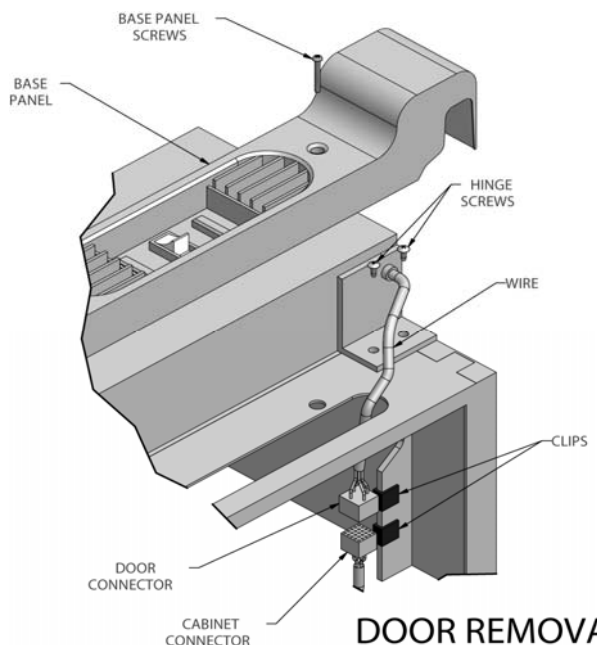

MAINTENANCE

PERIODIC CLEANING

Disconnect the power supply before cleaning the freezer.

Beginning with the initial installation, the interior surfaces of the cabinet should be periodically wiped down with a solution of warm water and baking soda (two tablespoons in one quart of warm water). This solution will remove any odors from spillage that has occurred. The exterior of the cabinet should also be cleaned frequently with warm water and a mild liquid detergent. **Caution: Do not use an abrasive or alkaline solution. Do not wash any removable parts in a dishwasher.**

Defrosting

This unit is a manual defrost freezer. During normal operation, it will build up a coating of frost/ice on the evaporator shelves. When the frost layer gets too thick (1/2 inch) it will affect the performance of the unit causing the internal temperature to rise. When this happens the unit will need to be manually defrosted. To manually defrost the unit, remove the product stored in the cabinet, block open the door and disconnect the unit from power.

CAUTION: Freezer must be unplugged to avoid electrical hazard from power source when defrosting the unit.

On upright models with a defrost drain (Figure 1), remove the drain plug on the interior floor of the freezer by pulling straight out. To access the external drain tube on models with the base panel, remove the two screws from the base panel. Locate the drain tube near the left center under the freezer. Place a shallow pan under the drain tube (pan not supplied). Defrost water will run out. Check the pan occasionally to ensure that the drain water does not overflow. A ½ inch garden hose adapter can be used to drain the freezer directly into a floor drain. If the model used is not equipped with an adapter, one can be purchased at most hardware stores. Replace the drain plug when defrosting and cleaning are complete. If the drain is left unplugged, warm air may enter the freezer.

Once all the frost has melted, wipe out the unit with a dry cloth, close the door and reconnect the unit to power. Allow four hours for the unit to return to proper operating temperature prior to reloading with product.

MAINTENANCE SERVICE AND ANALYSIS GUIDE

<u>MALFUNCTION</u>	<u>POSSIBLE CAUSE</u>	<u>SOLUTION</u>
Freezer does not run.	<ol style="list-style-type: none"> 1. Freezer plugged into a ground fault interrupt circuit. 2. Temperature control is in the OFF position. 3. Fuse blown or tripped circuit breaker. 	<ol style="list-style-type: none"> 1. Use another circuit. 2. See Temperature Control Section. 3. Check/replace fuse with a 15A time delay fuse. Reset circuit breaker
Freezer runs too much or too long.	<ol style="list-style-type: none"> 1. Freezer recently disconnected for a lengthy period. 2. Large amount of product recently stored. 3. Doors opened too frequently or too long. 4. Freezer door may be slightly open. 5. Temperature control set too cold. 6. Freezer gasket is dirty, worn, cracked or poorly fitted. 	<ol style="list-style-type: none"> 1. 4 hours required for freezer cool down. 2. Warm product will cause freezer to run more until desired temperature is reached. 3. Open doors less often. 4. Freezer may not be level. 5. Reset temperature control. 6. Clean or replace gasket.
Vibrating or rattling noise.	<ol style="list-style-type: none"> 1. Freezer not level. 2. Freezer is touching the wall. 	<ol style="list-style-type: none"> 1. Re-level the freezer as specified in the INSTALLATION section. 2. Move the freezer away from the wall.
Moisture forms on freezer interior.	<ol style="list-style-type: none"> 1. Weather is hot and humid. 2. Door not seating properly. 3. Door kept open too long or too frequently. 	<ol style="list-style-type: none"> 1. This is normal. 2. Re-level the freezer. 3. Open door less often.
Moisture forms on freezer exterior.	<ol style="list-style-type: none"> 1. Door may not be sealing properly. 	<ol style="list-style-type: none"> 1. Re-level the freezer.
Door will not close.	<ol style="list-style-type: none"> 1. Freezer is not level. 	<ol style="list-style-type: none"> 1. Re-level the freezer.
Light bulb will not turn on.	<ol style="list-style-type: none"> 1. Light bulb burned out. 2. No electric current reaching the Freezer. 3. Defective light bulb holder or Light switch. 	<ol style="list-style-type: none"> 1. Replace light bulb with a new bulb of the Same wattage. 2. Ensure freezer is plugged into power receptacle. 3. Contact a service technician.