ICE CREAM TOPPING CABINET MODELS ZR152, ZF152 & ZF071

Installation, Operation and Maintenance Instructions

Please read this manual completely prior to installing and operating this equipment. This manual describes how to install, operate and maintain the product to obtain the optimum in performance, efficiency and reliability.

TABLE OF CONTENTS

RECEIVING INSPECTION.....	2
SAFETY INFORMATION	3
SET-UP AND INSTALLATION	5
REVERSING THE DOOR SWING (27" SOLID DOOR MODELS)	8
START-UP AND OPERATION.....	8
CLEANING AND MAINTENANCE	10
TROUBLE SHOOTING GUIDE	11

RECEIVING INSPECTION

Congratulations on your purchase of a quality-built appliance. When properly installed and maintained this product will give many years of trouble-free service. It was shipped using trusted carriers with a history of careful handling, good customer service and prompt delivery.

Even with all these precautions taken, occasionally accidents may happen which result in shipping damage. When the product was picked up by the carrier they assume responsibility for the product until they deliver it to you. Thus, any claims for shipping damages must be filed with the delivering carrier.

Always thoroughly inspect the delivery for visible damages and shortages. Should any damages or shortages be found be sure to note them in detail on the delivery receipt before you sign off on it. Make sure the driver signs and dates the delivery receipt acknowledging the damages. This is critical in protecting yourself should a claim need to be filed. You can consult the carrier's website for their specific claim procedures. Remember it is your responsibility to file a claim with the carrier.

In the case of concealed damages that are not discovered in the initial inspection but are found upon removing packaging, time is critical. You should unpack and inspect the unit as soon as possible. If concealed damage is found, stop unpacking and contact the delivering carrier immediately to alert them of the damages and get a claim number. Save all packaging for inspection by the carrier. Consult the carrier website for details in filing a concealed damage claim.

Please remember, the carrier is your only source for reclaiming freight damages. The manufacturer should not be contacted to attempt a return of the product. No returns are accepted without a prior authorization.

SAFETY INFORMATION

This manual may contain notices that identify situations that could cause death, serious injury and /or damage to the appliance or property.

Please make note of the following definitions;

! WARNING Indicates a hazardous situation which could result in death or serious injury.

NOTICE Indicates a situation which could result in damage to the appliance or property.

IMPORTANT Indicates important information about the use and care of the appliance.

! WARNING

This appliance should be applied only for the use for which it has been expressly intended. Any other use would be considered improper and therefore dangerous. The manufacturer cannot be held responsible for injury or damage resulting from improper, incorrect and unreasonable use. Failures to install, operate, or maintain the appliance in accordance with this manual will adversely affect safety, performance, component life and warranty coverage.

To reduce the risk of death, electric shock, serious injury or fire, follow basic precautions including but not limited to the following;

- Only qualified service technicians should install and service this appliance.
- This appliance must be installed in accordance with applicable national, state and local codes and regulations.
- To reduce the risk of electrical shock, do not touch the appliance or plug with wet hands.
- Disconnect the appliance from power before servicing.
- The appliance requires an independent power supply of proper capacity. See the appliance nameplate for electrical specifications. Failure to use an independent power supply of proper capacity can result in a tripped breaker, blown fuse, damage to existing wiring or component failure. This could lead to heat generation or fire.
- The appliance must be properly grounded. This appliance is equipped with a NEMA 5-15P three prong grounded plug to reduce the risk of potential electrical shock hazards. It must be connected to a properly grounded, independent 3 prong wall outlet. Do not remove the ground prong from the appliance plug and do not use an adapter plug. Failure to follow these instructions may result in death, electrical shock or fire.
- Do not use an extension cord to supply power to the appliance.

- Do not use the appliance should the power cord become damaged. The power cord should not be altered, jerked, pinched, bundled and/or used to hang objects from. Such actions could result in electrical shock or fire. To disconnect the unit from power, be sure to grasp and pull on the plug, not the cord.
- Should the power cord require replacement or service, use only the manufactures replacement parts and be sure to connect the green ground wire to the appliance in the same manner the original wire was connected.
- Do not spray or splash water on the appliance as this may cause short circuits, electrical shock, corrosion or failure.
- Do not make alterations or modifications to the appliance as these could result in electric shock, injury, fire or damage to the appliance.
- Children must be properly supervised around this appliance.
- This appliance is not intended for use by persons (including children) with reduced physical, sensory or mental capabilities or lack of experience and knowledge unless they have been given supervision or instruction concerning its use by a person responsible for their safety.
- Do not climb, stand, or hang on or into the appliance or its components. Death or serious injury could occur or the appliance could be damaged.
- Use caution when opening doors or lids and keep fingers out of pinch points areas.
- Do not use combustible sprays or aerosols around the appliance as they may catch fire.
- Do not store gasoline or other flammable substances in or near the appliance as they may catch fire.
- Keep the area around the appliance clean. Dirt, dust or insects around the appliance could cause harm to individuals or damage to the equipment.
- Do not load the shelves with more than 100 pounds of load as they could fall and cause injury.
- Do not block air inlets or outlets as this would cause cooling performance to be reduced.
- Do not overload the storage capacity of the appliance. Allow space between stored items for air flow.
- Do not load warm or hot items into the appliance. Allow them to cool first or they will raise the cabinet temperature and could hasten the deterioration of other foods stored in the cabinet.
- This appliance is designed for the temporary storage to food products. Use proper sanitation practices.
- All food products should be covered or stored in sealed containers. Open foods may dry up, pass their smell to other foods and increase cross contamination. Some food products may accelerate corrosion of the evaporator resulting in failure of the appliance to cool.
- Component parts must be replaced with manufacturer original equipment parts.

SET-UP AND INSTALLATION

CAUTION

This unit uses a flammable refrigerant. Use care when handling and operating to avoid damaging the refrigerant tubing or increasing the risk of a leak.

! WARNING

This appliance must be installed in accordance with all applicable national, state and local regulations. This appliance is heavy. Use care when lifting and positioning. Work in pairs when needed to prevent injury or damage. This appliance is not intended for outdoor use. The store temperature should be at or below 75 F and a relative humidity of 55% or less. At higher temperature or humidity conditions, the performance of these cases may be affected and the capacity diminished. These cases should not be positioned where it is directly exposed to rays of sun or near a direct source of radiant heat or airflow. This will adversely affect the case and will result in poor performance. Operating conditions range from 45°F to 86°F (7°C to 30°C). Operating this appliance outside its range and installation requirements may affect performance and warranty coverage.

Caster/Leg Installation

NOTICE

The Casters or legs supplied with the unit must be installed for the unit to operate properly. If they are not installed the unit will not perform properly and the warranty will be void.

Once the appliance has been removed from its shipping container the casters or legs will need to be installed when applicable. The Casters or Legs can be found packaged inside the unit. Lay the unit on its back (protect the back surface to placing cardboard down first). Protect the power cord so that it does not get pinched or damaged. The plate style casters attach to the bottom of the cabinet with 4 (1/4-20) screws. The screws are already in the base. Remove the screws (Phillips screwdriver required) and use them to attach the casters. The Caster with the locks should be installed on the front of the unit. Be sure to tighten the screws snug to prevent them from coming loose. Optional legs attach similarly.

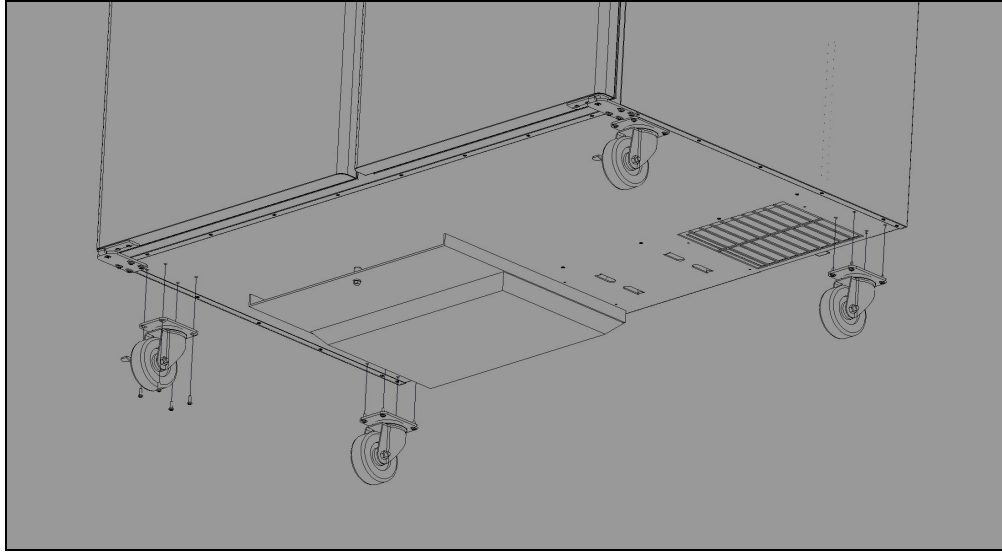

Air Duct/Condensate Pan Installation

NOTICE

Do not operate the unit without the Air Duct/Condensate Pan installed as the unit will not perform properly and will leak condensate water onto the floor and all warranties will be void.

The Air Duct/Condensate Pan assemble can be found packaged inside the cabinet. While the unit is laying on its back, install the Air duct/Condensate Pan assembly as shown below. The rear flange fits into the hole under the Condenser Coil and the hex head bolt screws into the threaded nut in the bottom of the cabinet.

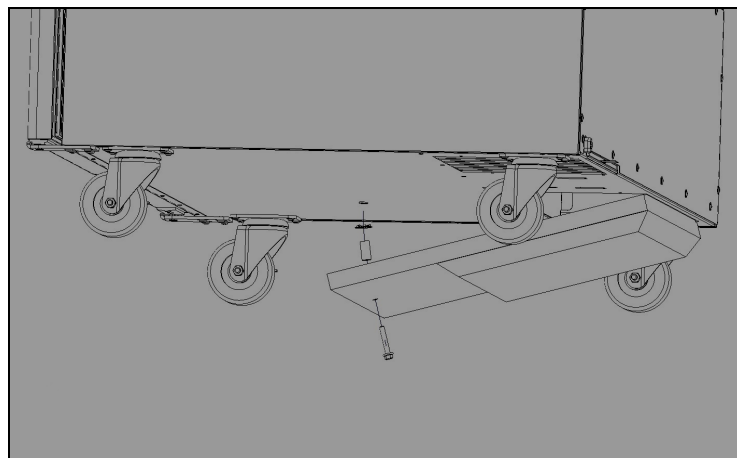

Once the Casters or Legs and Air Duct/Condensate Pan are installed the unit can be returned to its upright position. Be sure to work in pairs when returning the unit to the upright position.

NOTICE

Do not operate the unit for 1 hour after returning the unit to its upright position to allow the oil to settle in the Compressor.

Filter Screen Installation

This appliance comes equipped with an air intake Filter Screen. This Filter Screen comes installed on the cabinet as shown below. Confirm that the Filter Screen is in place prior to operating the unit.

NOTICE - Do not operate the unit without the Filter Screen in place.

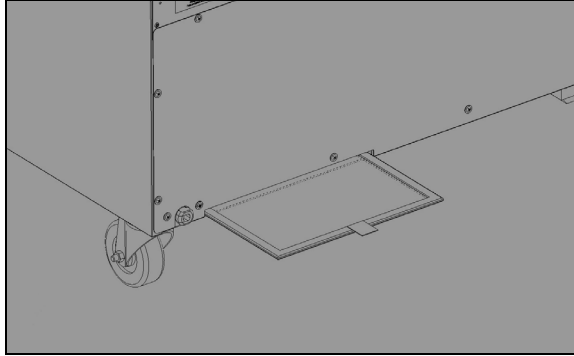

Shelf Installation

The appliance is supplied with one Shelf per door and four Shelf Supports per Shelf. Install the Shelf Supports on the Shelf Pilasters (factory installed on inside walls) at the height desired. All Shelf Supports must be at the same height for each Shelf. Install the Shelf on the Shelf Supports.

Locating the Appliance

This appliance is a zero-clearance front breathing unit. It can be installed with no clearance space on the sides and back. The unit needs to have casters or legs installed as well as the Air Duct/Condensate Pan to operate properly.

IMPORTANT

- Confirm that the floor in the installation location is strong enough to support the unit.
- Confirm that the ambient temperatures are within the tolerances allowed.
- Do not locate next to heat generating appliances.
- The unit is intended for indoor installation.
- Confirm the unit is installed level.
- Do not use an extension cord to connect the unit to power. Use of an extension cord will void all warranties.
- Do not tamper with the ground pin on the power cord and confirm that the power receptacle has a properly wired ground connection.
- The appliance must be isolated on a power circuit.
- Confirm that the power supply matches the required power supply noted on the cabinet serial plate.

Reversing the Door Swing (27" solid door models)

The 27" solid door models come standard with a right-hand hinged door. To reverse the door to left hand hinging follow the steps below;

1. Disconnect the unit from power.
2. Lay the unit on its back.
3. Remove the Bottom Hinge (4 screws) from the base of the cabinet and from the Hinge Cartridge (1 screw). Save the screws, Horseshoe Spring and Washer.
4. Lift the Door off the cabinet.
5. Remove the Top Hinge (2 screws) from the cabinet.
6. Relocate the Top Hinge to the top left side of the cabinet using the threaded insert provided and the 2 screws from step 5.
7. Remove the Hinge Cartridge from the bottom of the Door (2 screws). Once the screws are removed use a slotted screwdriver to pry the Hinge Cartridge out of the bottom of the Door.
8. Relocate the Hinge Cartridge to the bottom left of the Door. The square hole will need to have the foam insulation removed to allow the Hinge Cartridge to fit. Use a screw gun and a 4" long drill bit to remove the foam.
9. Relocate the Top Hinge Bushing to the top left hole in the Door.
10. Place the Door on the cabinet and insert the Top Hinge pin into the Hinge Bushing on the Door.
11. Secure the Bottom Hinge to the Hinge Cartridge (1 screw). The Bottom Hinge should be placed so it forms an angle of less than 90 degrees with relation to the Door. The Horseshoe Spring and Washer should be placed between the Hinge Cartridge and the Bottom Hinge.
12. Secure the Bottom Hinge to the cabinet using the 4 screws from step 3.
13. Return the cabinet to its upright position.
14. Check the Door to confirm the self-closing feature is operating properly. If it is not the Bottom Hinge is not installed properly to the Hinge Cartridge. Remove and re-install.
15. Wait one hour before re-connecting the unit to power.

START-UP AND OPERATION

After meeting the set-up and installation requirements the unit is ready to start-up. Once the power cord is connected to a live outlet the unit will start running. Allow the unit to run for two (2) hours prior to loading it with product.

Temperature Adjustment

The Temperature Control for the lower section is located on the inside back wall of the unit and comes pre-set to the mid-point position which will give internal temperatures of approximately +38° F for refrigerators and 0° F for freezers. Should you require a warmer cabinet temperature turn the temperature control counter-clockwise or if you require cooler temperatures turn the control clockwise. Adjust the control in small

increments at a time and allow the unit sufficient time to respond fully to temperature adjustments.

The rail section operates independently of the lower storage section. There is an on/off switch for the rail on the front right side of the rail (marked Rail Only). Use this switch to turn off the rail when not in use or to defrost the cold wall rail section. The temperature control for the rail is located behind the right-side panel on the rail. To adjust the temperature of the rail, remove the rail end panel and locate the rail temperature control. Turn the temperature control clockwise for cooler rail temperatures and counterclockwise for warmer rail temperatures. Allow several hours for rail temperature adjustments. Product should be removed from the rail during extended periods of non-use. The rail section is designed to keep products cool not pull them down so product loaded in the rail should be down to temperature prior to putting it in the rail section. The rail section will build up ice on the walls and should be shut off to defrost. Do not operate the rail unless it is filled completely with jars to minimize ice buildup.

Loading Product

Once that cabinet has been operating at the desired temperature for a sufficient period of time, product can be loaded into the cabinet. Prior to loading product adjust the shelving to the desired position.

IMPORTANT

When loading product use caution not to block airflow to achieve maximum cooling performance.

Do not load product where it would block the air intake or discharge at the back inside wall of the cabinet.

Do not load warm product into the cabinet as it will affect the cabinet temperature and products previously stored in the cabinet.

Products should be in covered containers or wrapped to prevent cross contamination.

Defrost

ZR152 model:

These units have "Off Cycle" defrost. The lower storage section of the unit will defrost automatically during each off cycle of the Compressor.

ZF152 and ZF071 models:

These units have timed electric defrost. The lower storage section will automatically go into a timed defrost every 8 hours where an electric heater will defrost any frost that has built up on the Evaporator Coil.

CLEANING AND MAINTENANCE

All service should be performed by factory authorized personnel. All component parts shall be replaced with like components to minimize the risk of possible ignition due to incorrect parts or improper service.

! Warning

Disconnect the unit from the power supply prior to conducting any maintenance, cleaning or servicing the appliance. Only re-connect the power when finished with the job.

Do not spray or splash any water directly onto the appliance.

Important

Do not use caustic chemicals when cleaning the appliance.

Do not use acidic cleaners when cleaning the appliance.

Do not use chlorinated cleaners on the stainless steel as this can lead to corrosion.

Do not use scouring or abrasive pads on the stainless steel.

Use only mild soap or stainless steel cleaners and soft cloth when cleaning.

Cleaning

Exterior and Interior Surfaces

Use stainless steel cleaners or mild soap/warm water solution and a soft cloth to clean the cabinet exterior. Wipe with the grain of the metal to avoid scratches. Do not use abrasive cleaning pads.

A Baking Soda solution can be used to help remove odors on the interior.

Shelves

Remove the shelves from the cabinet and clean with a soft cloth or brush and mild soap/warm water in a sink.

Door Gasket

Door Gaskets should be cleaned periodically with the mild soap/warm water solution to remove any debris collected in the bellows. The gasket can be easily removed if necessary by pulling it out of the groove starting at the corners. Replace by pushing the gasket dart back into the groove starting at the corners.

Maintenance

Filter Screen

The Filter Screen must be cleaned regularly to maintain the product performance. Dirty/clogged Filter Screens and Condenser Coils will result in compressor failure and/or performance loss and void all warranties. The Filter Screen is located on the back of the cabinet near the bottom left side. To remove the Filter Screen gently pull straight

out on the Filter Screen tab. The Filter Screen should be washed gently in a sink with a mild soap/warm water solution or by running a gentle stream of water through the filter. Replace the Filter Screen in the cabinet after cleaning.

NOTICE - Do not operate the unit without the Filter Screen installed!

Drain Pan/Air Duct

Occasionally the Drain Pan/Air Duct should be inspected and cleaned to remove any build up debris. To remove the Drain Pan/Air Duct remove the fastener at the front of the Drain Pan and pull the assembly out the front of the cabinet. Clean the assembly with a mild soap/warm water solution. Replace the Drain Pan Air Duct in the cabinet after cleaning.

NOTICE - Do not operate the unit without the Drain Pan/Air Duct installed!

TROUBLE SHOOTING GUIDE

Problem	Remedy
Compressor will not start	<ul style="list-style-type: none">· Check the power cord and make sure it is plugged in.· Check the power supply to confirm power to outlet.· Check the temperature controller. If it is in the "OFF" position, turn it clockwise to set a desired temperature.· Confirm unit is isolated on a power circuit.
Poor performance	<ul style="list-style-type: none">· Move the unit from direct sunlight.· Move the unit away from heating devices.· Install the unit in a well-ventilated place,· Clean the Filter Screen if heavy dust is collected.· Clear contents from blocking the Drain Pan/Air Duct.· Check the Temperature Control for incorrect setting.· Check the refrigerant level, it may need to be charged.· Check the door and be sure it is completely closed.· Check the Door Gasket condition.· Check product load to confirm good airflow in cabinet.· Check fans to confirm all are working and not missing blades.
Unit noisy	<ul style="list-style-type: none">· Install the unit on a level surface.· Check for loose part or mounting.· Keep the tubing free from any contact to avoid rattle.· Check fans to confirm all are working and not missing blades.
Condensation on cabinet exterior	<ul style="list-style-type: none">· Reduce humidity where the unit is installed.